

# PRECISION LEAD SCREW ASSEMBLIES



*Universal* 

THREAD GRINDING COMPANY

## CHECK OUR WEBSITE

[www.universal-thread.com](http://www.universal-thread.com)

Universal's site on the worldwide web, at [www.universal-thread.com](http://www.universal-thread.com), offers you 24 hours a day, up-to-date information including detailed product specifications and customized services.

In addition, our website includes:

- Application notes on banding
- A check off list to help you specify *Universal* Lead Screw Assemblies



## About Universal

**Universal Thread Grinding Company**, located in Fairfield, CT, USA, offers high quality lead screw assemblies for precision, linear positioning applications.

Universal Thread was founded in 1946 to meet the needs of regional manufacturers by providing a wide range of customized thread grinding services. Development of expertise in manufacturing precision lead threads guided the evolution of our current product lines of precision lead screw and nut assemblies. For over 25 years the *Universal* lead screw assembly has been used worldwide, meeting the most demanding requirements.

Building the best lead screw assembly is Universal Thread's only mission. Whether you specify a standard product from our extensive stock, or require a customized product, you will get the full attention of our experienced staff.

Call us to discuss your specific requirements. Or visit our website, at [www.universal-thread.com](http://www.universal-thread.com). Our e-mail response form will help you specify a customized lead screw assembly to meet your applications. Our Connecticut plant is fully stocked and ready to respond to your most immediate needs. We offer our years of experience, attention to detail, personal service, and on time delivery.



**PRECISION LEAD SCREW ASSEMBLIES**



**LEAD SCREW CARTRIDGE ASSEMBLIES**



**DUAL THRUST LEAD SCREWS**

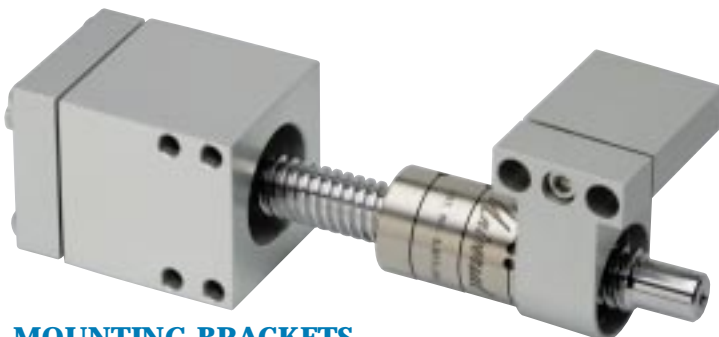

**MOUNTING BRACKETS**

**PAGE**

**ABOUT  
UNIVERSAL ...** 2

**PRECISION  
LEAD SCREW  
ASSEMBLIES** 4-7

**LEAD SCREW  
CARTRIDGE  
ASSEMBLIES** 8-9

**DUAL THRUST  
LEAD SCREWS** 10-11

**MOUNTING  
BRACKETS** 12

**HOW TO SPECIFY  
*Universal*  
LEAD SCREW  
ASSEMBLIES** 13

**QUALITY  
CONTROL** 14-15

# PRECISION LEAD SCREW ASSEMBLIES

*We will be glad  
to help you specify  
the lowest cost unit  
that will meet your  
requirements.*

Universal Thread Grinding offers a comprehensive selection of standard precision lead screw assemblies. Installed with ordinary skills and equipment, *Universal* lead screw assemblies deliver their full rated accuracy. Applications include single or multiaxis positioning tables, instruments, or precision scanning mechanisms.

Universal's precision components are factory assembled, preloaded, and "run in" under ideal conditions. The patented self-aligning\* and self-adjusting\* nut and thrust bushing will accommodate and reduce the effects of misalignment and slide errors to bring out the best in stepping motor or servo systems.



#### **ACCURACY:**

Standard: 0.000050"/turn, 0.000100"/inch

Available: 0.000010"/turn, 0.000025"/inch

#### **STOCK SIZES:**

1/4" diameter, travel to 8"

1/2" diameter, travel to 25"

3/4" diameter, travel to 31"

#### **STANDARD LEADS:**

Commonly used leads from 0.025" to 0.400", 1 mm to 5 mm.

Nonstandard leads quoted to your order.

\*U.S. Patent Numbers: 3,977,269; 3,831,460; 4,434,677

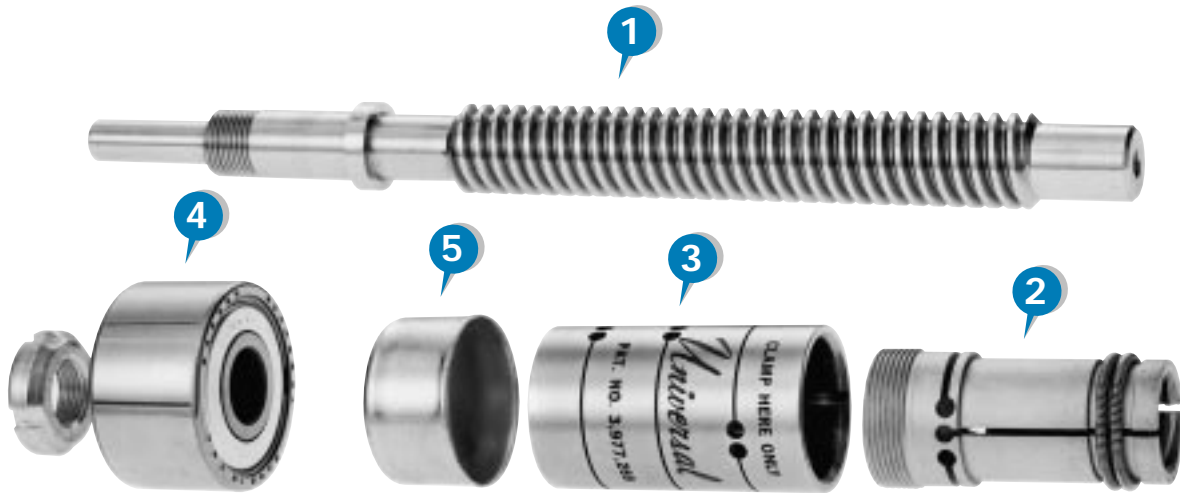

**1 PRECISION LEAD SCREW**

Manufactured of hardened, low temperature stabilized A6 tool steel, in four accuracy grades. Threads are ground and lapped. Thread to thread error as low as 0.000010" including drunkenness. Each screw is "run in" with its own nut.

**2 PRELOADED NUT**

One piece phosphor bronze split nut is self-adjusting. Radially preloaded nut halves respond to the average lead, further reducing residual one turn screw errors. Improved design achieves increased axial stiffness and suppresses backlash.

**3 SELF-ALIGNING THRUST BUSHING**

Multiflexured, one piece bushing transfers thrust from the nut to the external load in a theoretically ideal way. Reduces effects of residual eccentricity of lead screw and errors due to slide nonlinearity. Minimizes loading of air bearing slides.

**4 THRUST BEARING**

Precision preloaded double row ball thrust bearing, in a selection of axial thrust accuracies as good as 0.000010". Thrust bearing error adds directly to the lead screw drunkenness error. Lead screw performance is compromised unless a bearing with equally small errors is selected and properly fitted. We select the best

available, epoxy them in place, and retest after fitting. We can also advise you on practical techniques to achieve extreme thrust accuracies better than 0.000005".

**5 OPTIONAL LUBRICATOR**

The optional lubricator, factory installed on the nut, removes dust and lubricates the screw in applications where the screw is exposed and continuous lubrication cannot be provided. Periodic reoiling of the lubricator is required; we can supply the recommended oil.



*All lead screws are shipped fully assembled and "run in" to intimately mate the screw and nut.*

# PRECISION LEAD SCREW ASSEMBLIES

## INSTALLATION

### SHAFT COUPLING

A flexible antibacklash coupling is needed between the drive motor and lead screw to isolate the motor bearing errors from the lead screw bearing. Metal bellows type couplings have been used successfully. Split clamps are recommended to prevent loosening by motor torque.

### LUBRICATION

The lead nut requires proper lubrication for peak performance and longevity of the **Universal** lead screw assembly. Our B-3 lead screw oil provides the required boundary lubrication on the nut / screw interface, and offers excellent wear protection and uniform torque transition from static to dynamic conditions. The B-3 oil film must be periodically replenished, a procedure which may be accomplished by oil bath immersion, automatic application, or manual oiling on a maintenance schedule determined by the application parameters. Universal Thread's optional lubricator for the lead nut may be incorporated to extend the maintenance interval.

Universal Thread's own light grease, specified KS-46, provides exceptional performance in many applications. The KS-46's torque and wear characteristics are excellent, and required relubrication is less frequent than with oil.

Universal Thread has provided lubrication systems for special environments (e.g. vacuum, cryogenic, etc.). Please contact the factory with your special requirements.

### MOUNTING

The lead screw must be rigidly mounted precisely parallel to the direction of motion.

The O.D. of the thrust bearing must be a sliding fit in its bore, and must be clamped axially only.

When the travel is six inches or less the thrust bearing provides adequate radial support, and a bearing at the outboard end may be omitted.

When the travel exceeds six inches we recommend a radial bearing to support the outboard end. Free axial movement at this bearing must be permitted.

In every case the nut clamp area must be fully and rigidly supported by the other slide member. Coaxial alignment of the clamp area with the lead screw must be preserved within 0.002".

## SPECIFICATIONS

Lead screw material — A6 hardened and low temperature stabilized.

Lead Screw Diameter	1/4"	1/2"	3/4"
<b>Maximum Available Travel</b>	8"	25"	31"
<b>Standard Leads*</b>	.025", .050", .100", .200", 1 mm, 2 mm, 4 mm	.025", .040", .050", .100", .125", .200", .400" 1 mm, 1.25 mm, 2 mm, 2.5 mm, 4 mm, 5 mm	.025", .050", .100", .200", 1 mm, 2 mm, 2.5 mm, 5 mm
<b>Maximum No-Load Torque</b>	4 oz in	8 oz in	12 oz in
<b>Maximum Load (Including Inertial)</b>	30 lb	50 lb	100 lb
<b>Working Load (Including Inertial)</b>	8 lb	10 lb	20 lb
<b>Stiffness of Nut</b>	4 lb /.0001"	5 lb /.0001"	8 lb /.0001"

\*OTHER LEADS AVAILABLE BY SPECIAL QUOTE.

### Lead Accuracy Specifications

"X"	"XX"	"XXX"	"XXXX"
.000050"/ turn	.000025"/ turn	.000010"/ turn	.000010"/ turn
.000100"/ inch	.000050"/ inch	.000025"/ inch	.000025"/ inch
.0004"/ foot	.0002"/ foot	.0002"/ foot	.0001"/ foot

### Bearing Thrust Plane Accuracy

<b>Standard</b>	—	.000030"
<b>Available</b>	—	.000015", .000010"



We will be glad to review your application and help you specify the lowest cost unit that will meet your requirements. We can advise you on special techniques to increase axial stiffness, and to achieve thrust plane accuracies better than 0.000005".

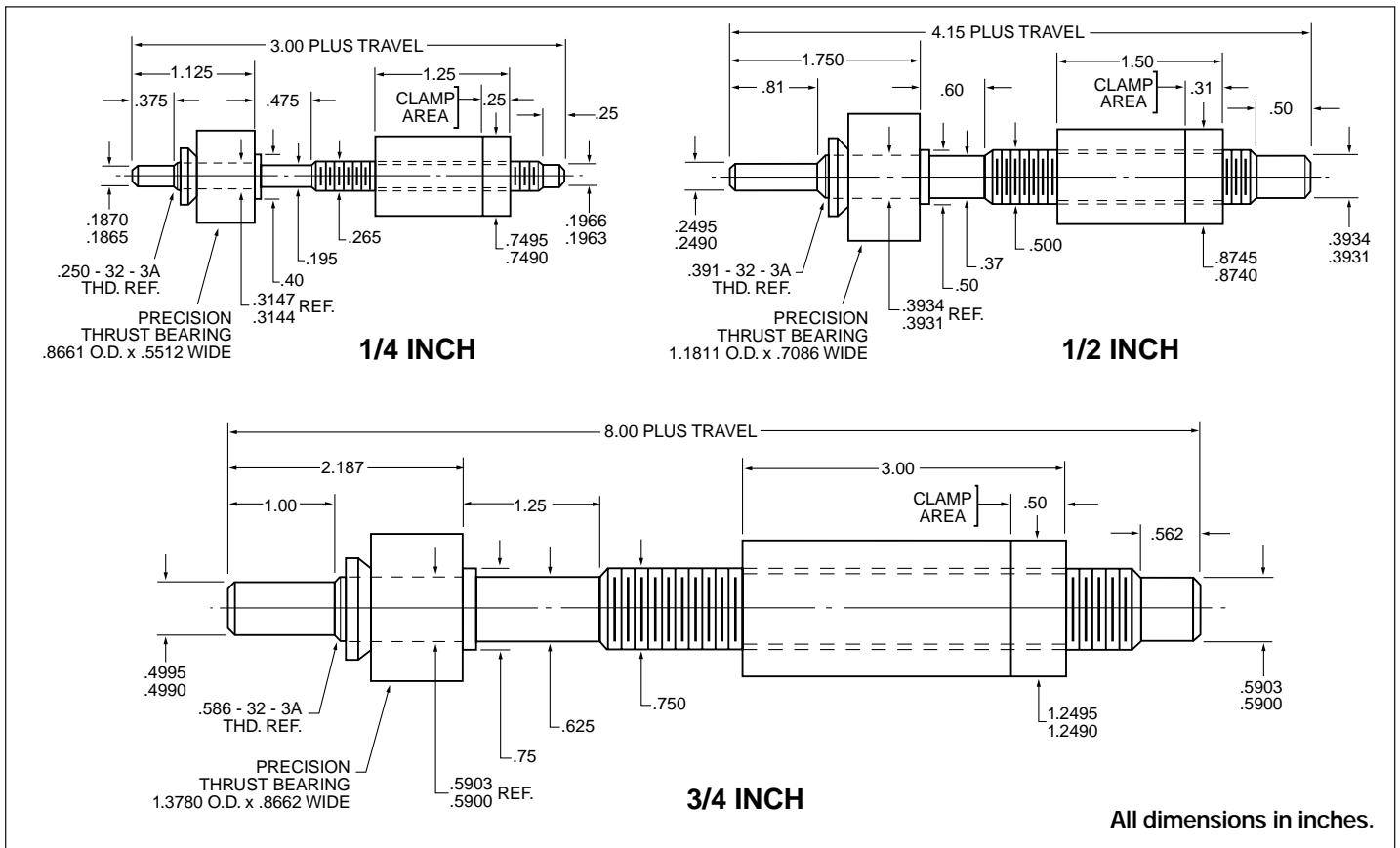

**NOTES:**

1. Nut can be factory assembled facing either direction, with clamp area closest to thrust bearing or away from thrust bearing. NUT ASSEMBLY MUST NOT BE REMOVED. Specify desired orientation when ordering.
2. Optional lubricator is installed on end of nut opposite clamp area. Must be factory installed when lubricator end of nut faces thrust bearing. Adds .38" to length of 1/4" nut and 1/2" nut, and .50" to 3/4" nut, which may reduce travel and/or restrict installation options in some cases.

**ORDERING AND CUSTOM CONFIGURATION:**

Please see page 13 "How To Specify *Universal* Lead Screw Assemblies."

# LEAD SCREW CARTRIDGE ASSEMBLIES

## BENEFITS

### ACCURACY

All accuracy grades available in 1/2" lead screws can be provided. Self-aligning, self-adjusting nut and thrust member minimize effect of slide errors.

### ENCLOSED HOUSING

Excludes dust and chips, and provides mechanical protection. Precision components are not exposed.

### PERMANENT ALIGNMENT

Lead screw, nut, and bearings are factory assembled and mounted under ideal conditions, and retested for accuracy after mounting. Alignment is not disturbed when you install the cartridge.

### EASY INSTALLATION

Simply bolt cartridge to flat surface and clamp or bolt thrust member to the other slide member. Bank against any cartridge edge for alignment. Misalignment with user parts is accommodated without backlash by flexural hinges in thrust member. Optional factory installed motor bracket supports motor in proper alignment with shaft.

### OIL BATH LUBRICATION

Constant supply of oil to the nut greatly increases working life.

### INCREASED STABILITY

Oil filled housing acts as a heat sink. Dissipates heat as it is generated, maintains equilibrium with surroundings, and minimizes effects of thermal transients and gradients.

### CONSTANT TORQUE

Improved lubrication results in increased efficiency and constant torque over a wide range of rpm.

Enclosed, oil filled lead screw cartridges provide simple installation, extreme accuracy, and long life in a wide range of lead screw applications. Each cartridge contains a standard 1/2" diameter *Universal* lead screw assembly, factory installed in a compact aluminum alloy housing. As the screw is rotated, the nut drives the thrust output member parallel to the screw axis. Axial and side arm output configurations permit the cartridge to be mounted in line with or beside the slide.

*Two cartridge configurations are available.*

*Each offers specific advantages in its own range of applications.*

## AXIAL

Output thrust is delivered coaxially with the lead screw via a self-aligning thrust tube that emerges from the end of the housing opposite the input shaft. Supplied in 2", 4", and 6" travel lengths. Thrust tube seal permits operation in any position. An air vent must be provided. Totally enclosed axial cartridge is ideal for central mounting between slide ways on slide centerline.

## SIDE ARM

Output thrust is delivered via a rigid arm clamped to the nut and emerging through a window that extends along the top face of the housing. Horizontal, upright mounting only, to retain oil bath. When mounted on the side of a slide table, the overall length, including the motor in most cases, will not exceed the length of the table. Available in 2", 4", and 6" travel lengths. Side arm cartridge permits travel to 6" without adding to overall length of slide table.



*Optional factory installed motor bracket replaces cartridge end cap. Supports most standard stepper and servo motors in alignment with lead screw. Factory assembly assures correct alignment and sealing integrity.*



### THE AXIAL CARTRIDGE

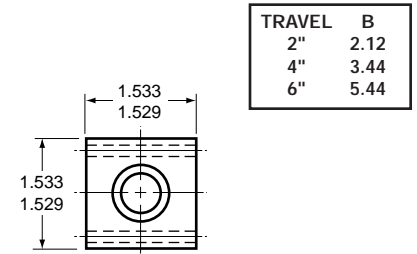
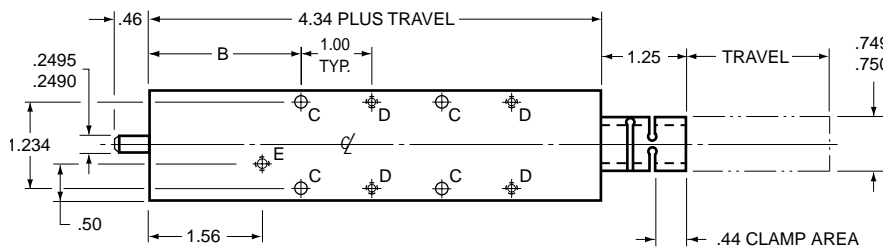

TRAVEL	B
2"	2.12
4"	3.44
6"	5.44

All dimensions in inches.

See specifications, page 6, for 1/2" lead screws.

### THE SIDE ARM CARTRIDGE

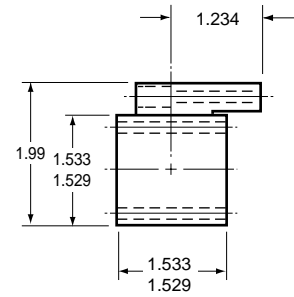
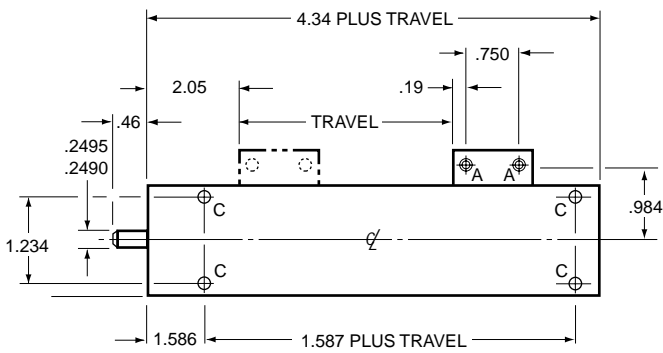

#### MOUNTING HOLES

- A .185 DIA. THRU. C'BORE FOR #8 SOCKET HEAD
- C .185 DIA. THRU
- D 8-32 UNC BOTH SIDES

#### OIL RESERVOIR HOLES

- E 1/8" NPT. 4 HOLES ONE EACH SIDE

#### NOTES:

1. Bank on any edge.
2. .002" maximum parallel mounting misalignment permitted between travel and thrust member clamp.
3. Use minimum of 4 mounting holes for proper mounting stiffness.
4. For use with optional motor adapter bracket, add 1.85" to left end for NEMA 23 motor size to locate motor mounting surface. Add 1.98" to left end for NEMA 34 motor size to locate motor mounting surface.
5. Travel 2.0", 4.0", or 6.0" axial or side arm configuration.

## INSTALLATION

Installation is simple and easy. Refer to drawings for dimensions and tolerances. Follow normal practices for handling and installing precision machine components.

1. Provide flat mounting and banking surfaces parallel to direction of travel. Attach cartridge using threaded or through holes, as convenient.
2. The clamp area of the thrust tube or thrust arm must be fully and rigidly supported by the other slide member.

**2a.** (Axial Cartridge). Clamp the free end of the thrust tube to the other slide member coaxially with the lead screw. Use a split clamp to prevent rotation and transfer the thrust force to the member.

**2b.** (Side Arm Cartridge). Bolt the thrust arm to a flat surface on other slide member.

**3.** Mount the motor coaxially with the lead screw, using optional motor bracket or other means.

**4.** Couple the motor shaft to the lead screw using a precision flexible coupling. Use split clamps to prevent loosening by torque pulses.

# PRECISION DUAL THRUST LEAD SCREW ASSEMBLIES

Universal manufactures high quality lead screw assemblies to meet your most demanding micro positioning applications. Our new dual thrust lead screw assemblies, containing two thrust nuts, allow users to execute equal and opposing precision linear motion with one drive system.

Each thrust nut on the lead screw features our patented, phosphor bronze split nut. One nut has a left hand thread; the other nut has a right hand thread. As the lead screw turns, the thrust nuts move uniformly in opposite directions from a fixed center line reference. Clockwise lead screw rotation moves the thrust nuts an equal distance away from the center line. Counterclockwise rotation moves the nuts an equal distance toward the center line.

Universal's dual thrust lead screws feature the same high lead accuracies offered by our single thread lead screws. Specify lead accuracies to 10 microinches/turn, 25 microinches/inch. Our standard 1/2" dual thrust lead screws, with up to 6" travel (for each nut), offer lead accuracies of 50 microinches/turn, 100 microinches/inch.

The lead screw's self-adjusting, preloaded nut reduces effects of misalignment and eliminates backlash. By eliminating backlash, repeatability is maximized. Dual thrust lead screw applications include high precision gaging, inspection, and assembly operations.

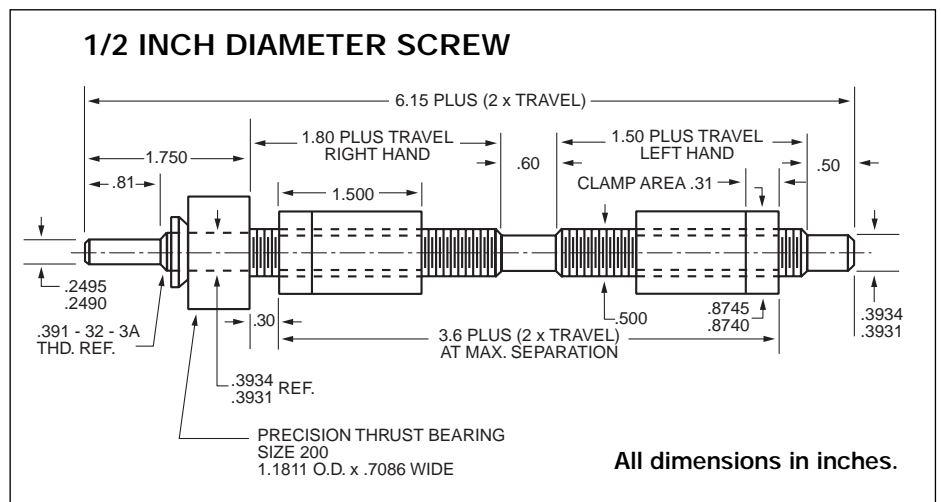

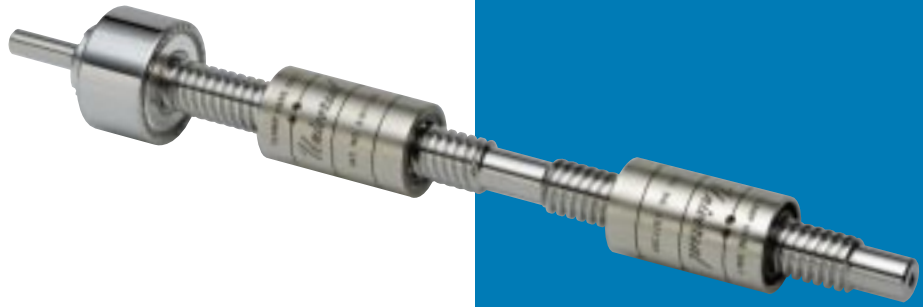

## SPECIFICATIONS

### LEAD SCREW

<b>Lead Screw Diameter</b>	1/2"
<b>Lead Accuracy</b>	
Standard	0.000050"/turn, 0.000100"/inch
Available	0.000010"/turn, 0.000025"/inch
<b>Bearing Thrust Plane Accuracy</b>	
Standard	0.000030" TIR
Available	0.000010" TIR
<b>Standard Travel</b>	
Each Nut	2", 4", 6"
<b>Standard Leads</b>	0.025", 0.050", 0.100", 0.200", 2 mm
<b>Lead Screw Material</b>	A6 hardened and low temperature stabilized

### LEAD NUT

<b>Max. No-Load Torque</b>	8 oz in per nut
<b>Max. Load</b> (Including Inertial)	50 lb
<b>Working Load</b> (Including Inertial)	10 lb
<b>Stiffness of Nut</b>	5 lb/0.0001"

### ORDERING:

Specify lead, travel, and accuracy required. Mounting brackets can be specified separately. Nonstandard leads can be supplied.

### NOTE:

Nut assemblies must NOT be removed.

## INSTALLATION

### SHAFT COUPLING

A flexible antibacklash coupling is needed between the drive motor and lead screw to isolate the motor bearing errors from the lead screw thrust bearing. Split clamps are recommended to prevent loosening by motor torque.

### LUBRICATION

Each thrust nut requires periodic lubrication. Universal can supply the recommended lubricant.

### MOUNTING

The lead screw must be rigidly mounted precisely parallel to the direction of motion. The O.D. of the thrust bearing must be a sliding fit in its bore, and must be clamped axially only. For travel of two inches or less, the thrust bearing provides adequate radial support, and a bearing at the outboard end may be omitted.

The nut clamp area must be fully and rigidly supported by the other slide member. Coaxial alignment of the clamp area with the lead screw must be preserved within 0.002".

### MOUNTING BRACKETS

Universal offers optional mounting brackets to simplify installation of the dual lead screw assembly. A thrust bearing bracket provides proper support and alignment for the thrust bearing. A motor bracket is available to use with the thrust bearing bracket for simple, pre-aligned motor support. The thrust bearing and motor brackets are factory assembled. Depending on the configuration, a nut bracket, assembled by the user, is available.

# MOUNTING BRACKETS

*Universal* lead screws are typically used to convert the controlled rotation of stepper motors and servo motors to extremely precise linear displacement. Coupled to commercially available precision slide tables, they permit the user to achieve very high accuracy without requiring special tools, facilities, or procedures.

Whatever the configuration, each machine designer must fulfill certain mounting and operation requirements. In many environments the mounting requirements are satisfied by simple brackets.

The main criteria includes:

- (1) stiffness
- (2) parallelism and colinearity of bearing and clamp bores with slide mounting planes



Universal mounting brackets provide proper support and alignment for the thrust bearing and the nut. The lead screw axis and nut clamp are accurately parallel to flat mounting and banking surfaces. The optional motor bracket can be used with the thrust bearing bracket for simple, prealigned motor support.

Each bracket is supplied separately. Order the thrust bearing bracket with the lead screw to permit factory assembly under ideal conditions. Order the optional motor bracket for factory assembly to the thrust bearing bracket.

Universal precision mounting brackets simplify design and fabrication. User provides a flat surface and Universal provides built-in mounting accuracy.

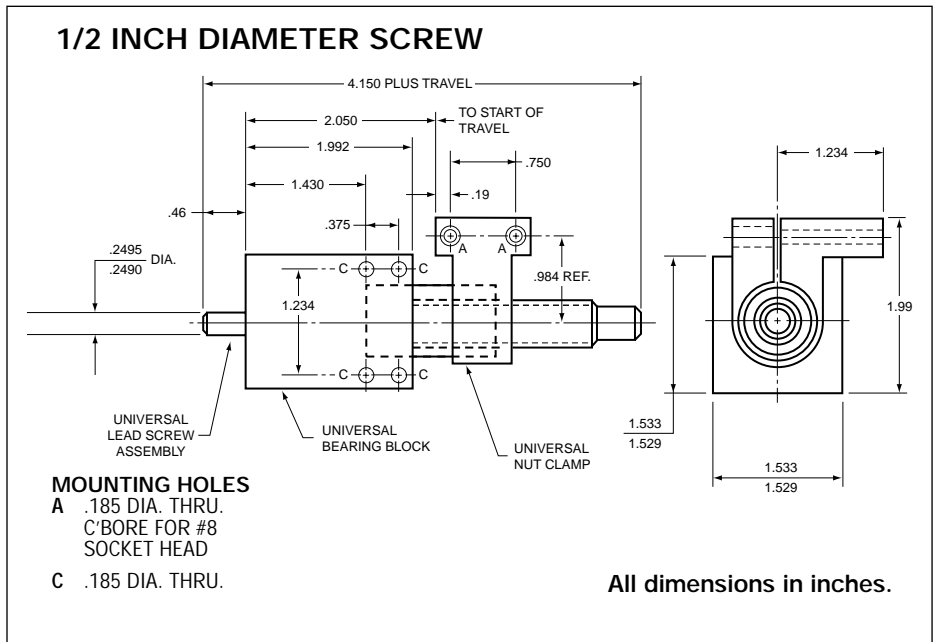

# CHECK OFF LIST TO HELP YOU SPECIFY *Universal* LEAD SCREW ASSEMBLIES

(See page 6 for specifications)

DIA.	<input type="checkbox"/> 1/4"	<input type="checkbox"/> 1/2"	<input type="checkbox"/> 3/4"
LEAD	<input type="checkbox"/> .025"	<input type="checkbox"/> 1 mm	<input type="checkbox"/> .025" <input type="checkbox"/> 1 mm
	<input type="checkbox"/> .050"	<input type="checkbox"/> 2 mm	<input type="checkbox"/> .040" <input type="checkbox"/> 1.25 mm
	<input type="checkbox"/> .100"	<input type="checkbox"/> 4 mm	<input type="checkbox"/> .050" <input type="checkbox"/> 2 mm
	<input type="checkbox"/> .200"		<input type="checkbox"/> .100" <input type="checkbox"/> 2.5 mm
TRAVEL	<input type="checkbox"/> 1"	<input type="checkbox"/> 2"	<input type="checkbox"/> 16"
	<input type="checkbox"/> 2"	<input type="checkbox"/> 4"	<input type="checkbox"/> 18"
	<input type="checkbox"/> 4"	<input type="checkbox"/> 6"	<input type="checkbox"/> 20"
	<input type="checkbox"/> 6"	<input type="checkbox"/> 8"	<input type="checkbox"/> 22"
	<input type="checkbox"/> 8"	<input type="checkbox"/> 10"	<input type="checkbox"/> 24"
		<input type="checkbox"/> 12"	<input type="checkbox"/> 25"
		<input type="checkbox"/> 14"	
		<input type="checkbox"/> 4" <input type="checkbox"/> 20"	
		<input type="checkbox"/> 6" <input type="checkbox"/> 22"	
		<input type="checkbox"/> 8" <input type="checkbox"/> 24"	
		<input type="checkbox"/> 10" <input type="checkbox"/> 26"	
		<input type="checkbox"/> 12" <input type="checkbox"/> 28"	
		<input type="checkbox"/> 14" <input type="checkbox"/> 30"	
		<input type="checkbox"/> 16" <input type="checkbox"/> 31"	
		<input type="checkbox"/> 18"	

# HOW TO SPECIFY *Universal* LEAD SCREW ASSEMBLIES

## Lead Accuracy

<input type="checkbox"/> "X" <input type="checkbox"/>	<input type="checkbox"/> "XX" <input type="checkbox"/>	<input type="checkbox"/> "XXX" <input type="checkbox"/>	<input type="checkbox"/> "XXXX" <input type="checkbox"/>
.000050"/ turn	.000025"/ turn	.000010"/ turn	.000010"/ turn
.000100"/ inch	.000050"/ inch	.000025"/ inch	.000025"/ inch
.0004"/ foot	.0002"/ foot	.0002"/ foot	.0001"/ foot

## Bearing Thrust Plane Accuracy

**Standard:**  .000030"  
**Available:**  .000015"  .000010"

## Nut Orientation

- Clamp closest to thrust bearing
- Clamp away from thrust bearing

## Lubrication

- B-3 Oil
- Brush Lubricator:  yes  no
- KS-46 Grease
- Special Conditions: Consult Factory

\*Restrictions may apply.

# *Universal* BUILDS QUALITY INTO PRECISION LEAD SCREW ASSEMBLIES

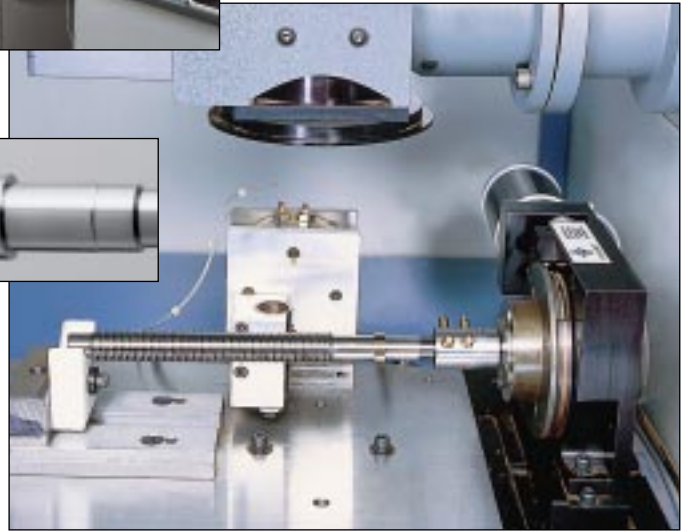

*Serial number, lead, and accuracy etched into lead screw and nut with a Laser Marking Machine.*



*Cutting a pallet of thrust bushings using Electrical Discharge Machining (EDM).*



*Lead screw hardness test using a Rockwell Hardness Tester. Maintains material quality and 100% reliability.*



*Drunkness checker measures deviation within one turn.*



*Inspection of bearing for thrust plane error.*

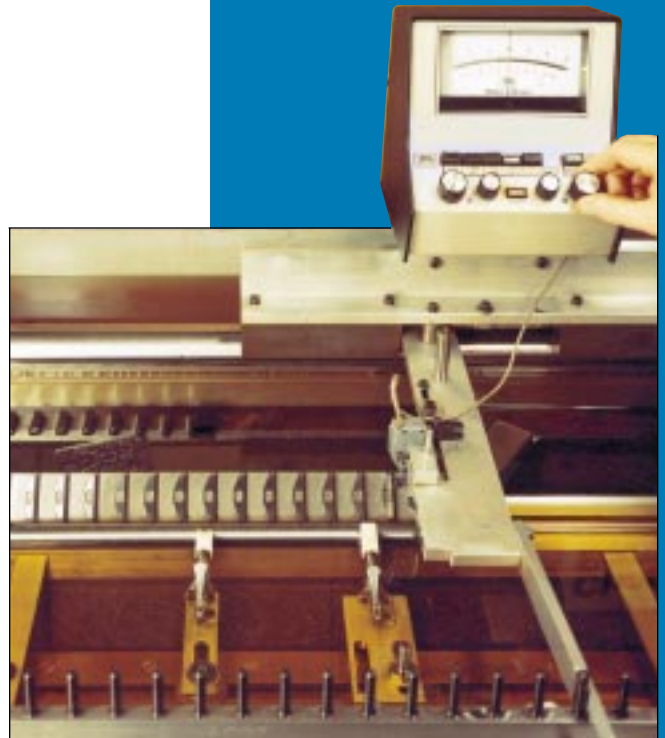

*Lead inspection in temperature controlled oil bath.*

Universal Thread provides traceability of its customers' products from original manufacture to delivery of the finished product to archiving.